

# Anti-condensation valve



01223/12 GB

## 280 series



### Function

The anti-condensation valve, used in heating systems with a solid fuel generator, automatically regulates at the set value the temperature of the water returning to the generator. Keeping the generator at a high temperature prevents condensation of the water vapour contained in the flue gas. It can be used both on boilers and residential generators such as fireplace heating systems, thermostoves and thermocookers. The anti-condensation valve gives the generator a longer life and ensures greater efficiency.

### Product range

280 series Anti-condensation valve

sizes DN 20 (3/4", 1"), DN 25 (1"), DN 32 (1 1/4")

### Technical specifications

#### Materials

Body: - DN 20: brass EN 12165 CW617N  
 - DN 25, DN 32: brass EN 1982 CB753S  
 Cap: brass EN 12164 CW614N  
 Obturator: PSU  
 Spring: stainless steel  
 Seal: EPDM  
 Union seals: non-asbestos fibre  
 Wax thermostatic sensor

#### Performance

Medium: water, glycol solutions  
 Max. percentage of glycol: 50%  
 Max. working pressure: 10 bar  
 Working temperature range: 5-100°C  
 Setting temperatures: 45°C, 55°C, 60°C, 70°C  
 Setting accuracy: ±2°C  
 By-pass complete closing temperature: Tset +10°C

Connections: 3/4" - 1" - 1 1/4" M (ISO 7/1) with union

### Dimensions

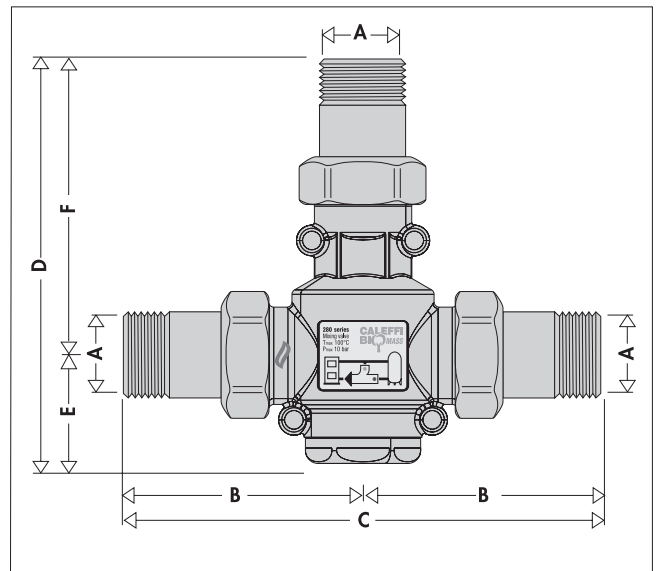

Code	DN	A	B	C	D	E	F	Mass (kg)
28005.	20	3/4"	67,5	135	105,5	29	76,5	0,750
28026.	20	1"	67,5	135	105,5	29	76,5	0,830
28006.	25	1"	88,5	177	153,5	42	111,5	1,650
28007.	32	1 1/4"	97	194	157	40	117	2,050

• Code completion				
Setting	45°C	55°C	60°C	70°C
•	4	5	6	7

### Wooden biomass and condensation build-up

Wooden solid fuel contains a variable moisture percentage depending on the type (logs, pellets, woodchips etc.) and seasoning. Water vapour is released during the solid fuel drying phase inside the combustion chamber. The presence of cold zones in the generator or flue gas chimney can lower the temperature of the flue gas down to the dew point, causing condensation to occur. Water vapour condenses on the generator surfaces, together with soot and part of the unburnt hydrocarbons contained in the flue gas, producing deposits and tar. These substances stick to the walls of the generator, covering most of the inner surfaces. In addition to being dangerous due to its flammability, tar is damaging to the integrity of the generator and limits the efficiency of the flue gas-system water exchanger.

By keeping the generator walls at the highest possible temperature, the anti-condensation valve limits the formation of these substances, thereby increasing the combustion efficiency, controlling the emissions into the environment and prolonging the generator life.

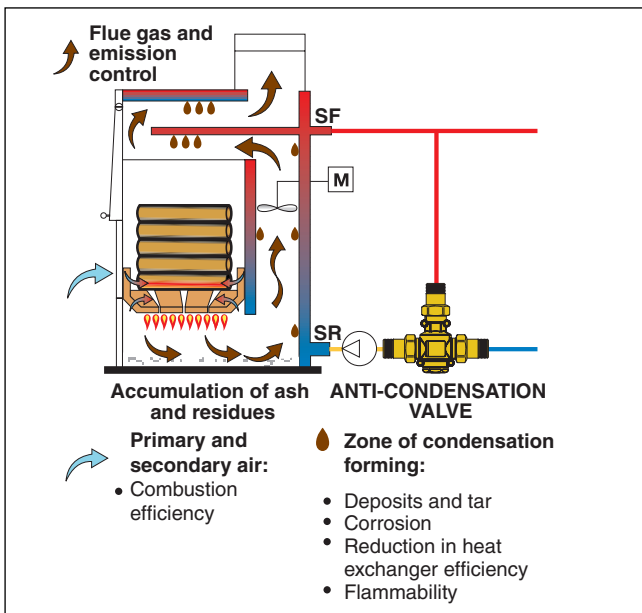

### Characteristic components

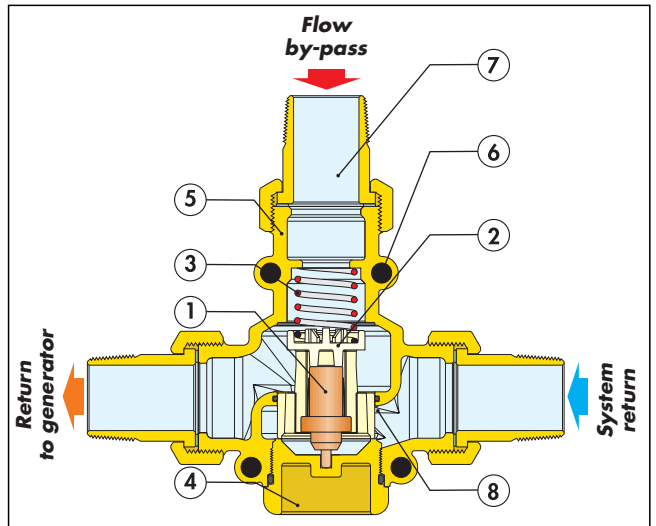

- |                        |                              |
|------------------------|------------------------------|
| 1) Thermostatic sensor | 4) Cap                       |
| 2) Obturator           | 5) Valve body                |
| 3) Spring              | 6) Temperature gauge holders |

### Operating principle

The thermostatic sensor ①, completely immersed in the medium, controls the movement of an obturator ② that regulates the flows in by-pass ⑦ and toward the system. At the start-up of the heat generator, the anti-condensation valve recirculates the flow water so as to bring the generator up to temperature as quickly as possible (fig. 1). When the flow temperature  $T_f$  exceeds the setting of the anti-condensation valve  $T_{set}$ , the valve's cold port ⑧ starts opening to produce the water mixing  $T_{mix}$ : in this phase the system loading begins (fig. 2).

When the return temperature to the generator  $T_{mix}$  is greater than the setting of the anti-condensation valve by approximately 10°C, the by-pass ⑦ port closes and water returns to the generator at the same temperature as the system return (fig. 3 and fig. 4).

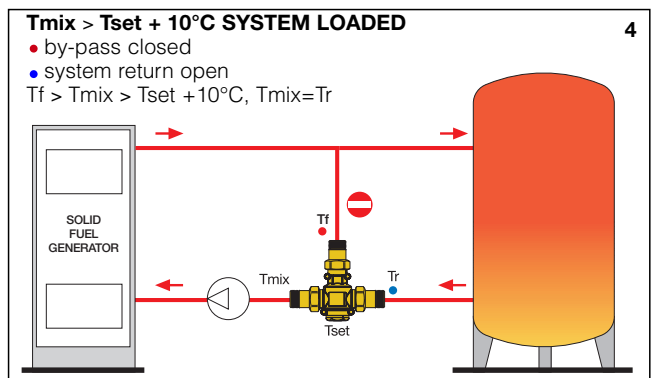
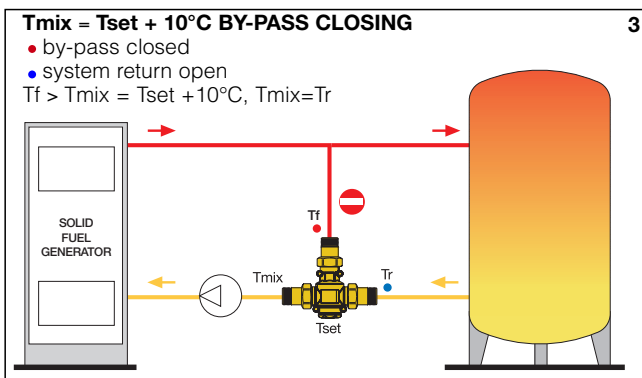
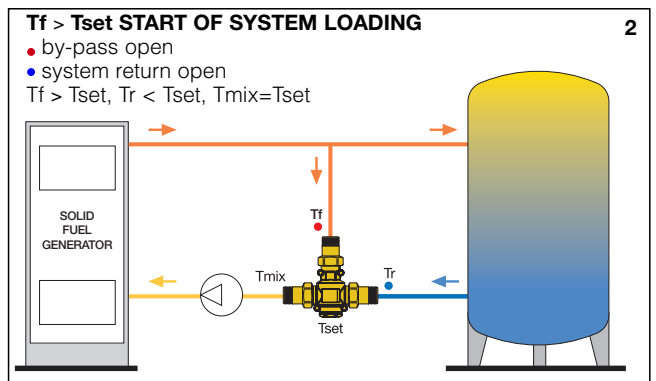
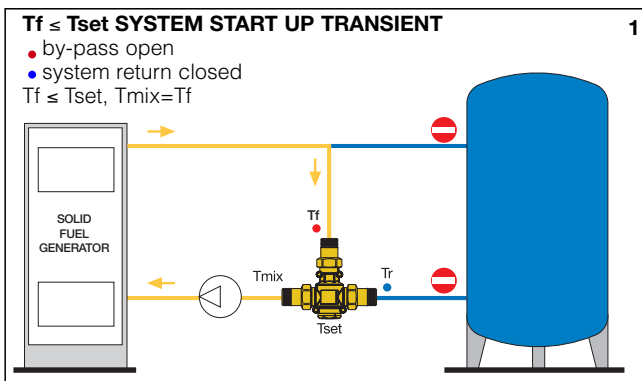

$T_f$  = Flow temperature  
 $T_{set}$  = Anti-condensation setting temperature

$T_{mix}$  = Mixed water temperature of generator return  
 $T_r$  = System return temperature

## Construction details

### Brass body

The brass body prevents the formation of ferrous residues in the system, thereby helping to prolong the life of the heat generator.

### Thermostatic sensor replacement for setting modification

The thermostatic sensor can be easily removed for maintenance or setting change.

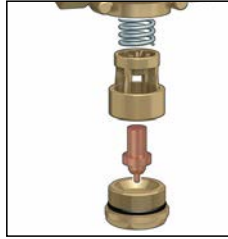

### Temperature gauge holders

The body of the anti-condensation valve in sizes DN 25 and DN 32 features temperature gauge holders on the front and rear sides. The holders allow the housing of code F29571 temperature gauges for controlling the working temperatures of the valve: by-pass water from the flow line, water returning from the system and mixed water returning to the generator.



## Hydraulic characteristics

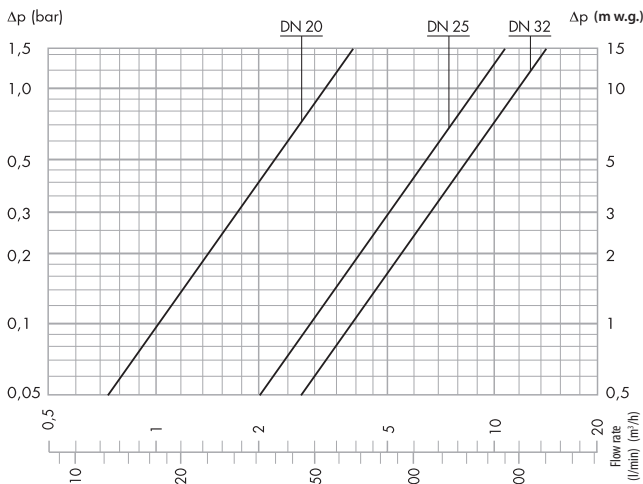

Size	DN 20	DN 20	DN 25	DN 32
Connections	3/4"	1"	1"	1 1/4"
KV (m³/h)	3,2	3,2	9	12

## Sizing method / Setting selection

According to the power output and thermal load on the heat generator, the flow rate provided by the generator can be calculated. With this value, it's possible to use the hydraulic characteristics diagram to obtain the head loss of the valve. The size is selected by evaluating the compatibility of the obtained head loss value with the available head of the system pump. The setting (°C) must be selected so as to guarantee a return temperature to the generator that is high enough to prevent condensation, also using the information or instructions supplied by manufacturers of solid fuel generators.

## Installation

The valve can be fitted on both sides of the generator in any position, vertical or horizontal. **Installation is recommended on the return to the generator in mixing mode;** it is also allowed on the flow from the generator in diverter mode according to the needs of system control.

### Installation in mixing mode (anti-condensation)

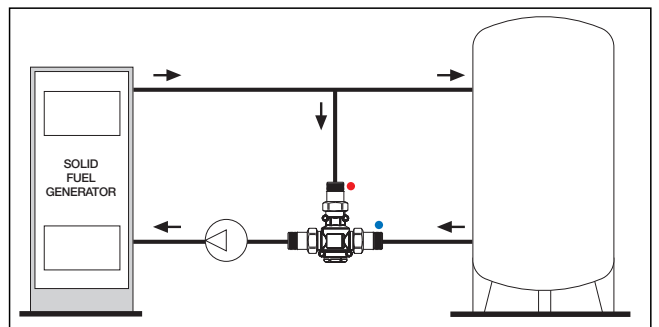

### Installation in diverter mode (system control)

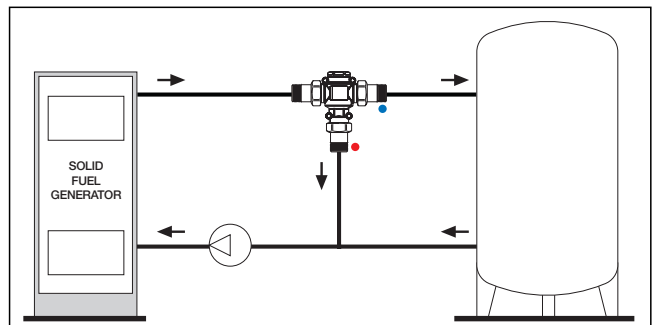

## Application diagram

### Solid fuel generator, direct supply to the system.

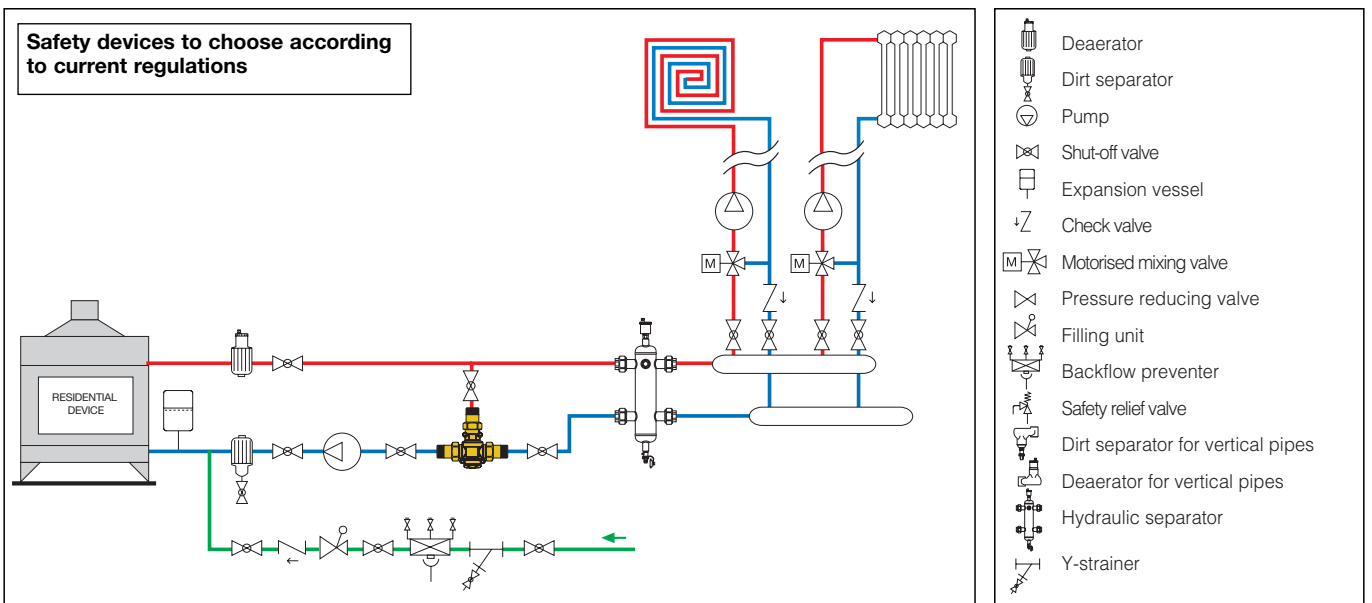

## System with inertial storage

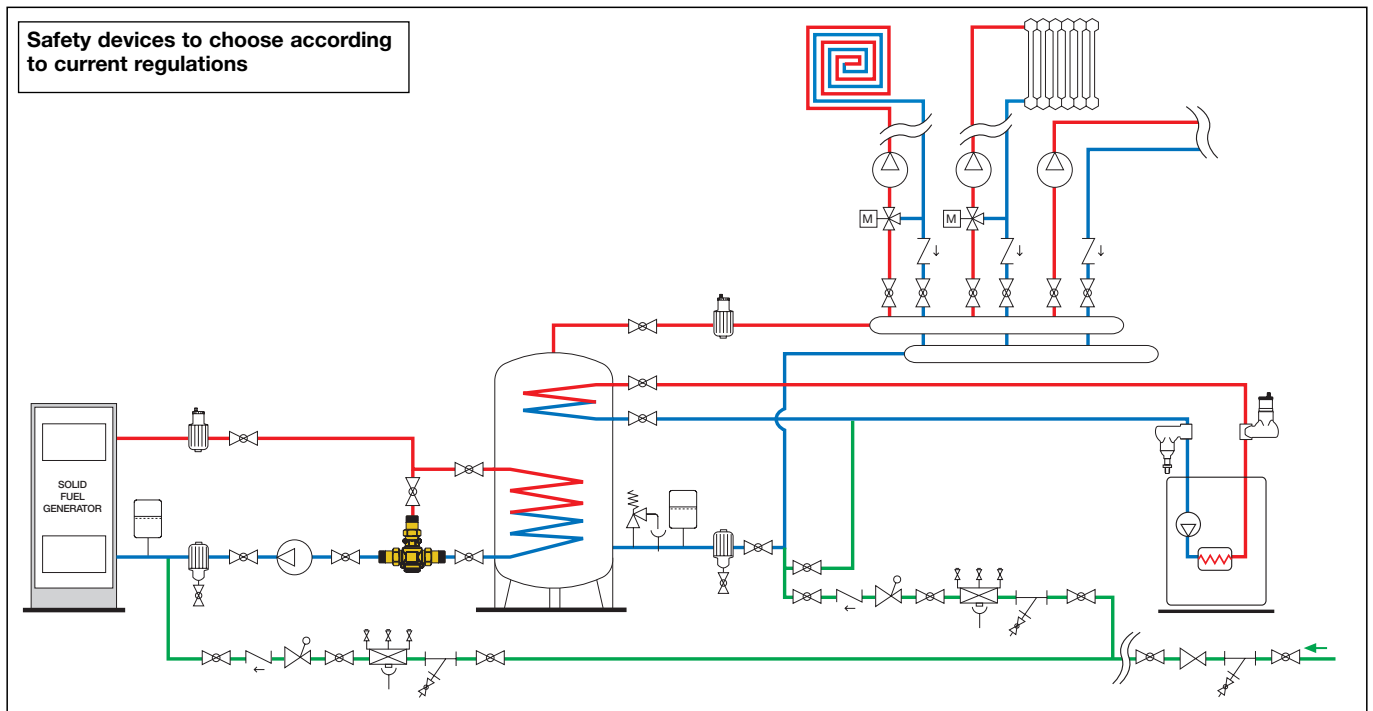

## Solid fuel generator, connection to inertial water storage in parallel.

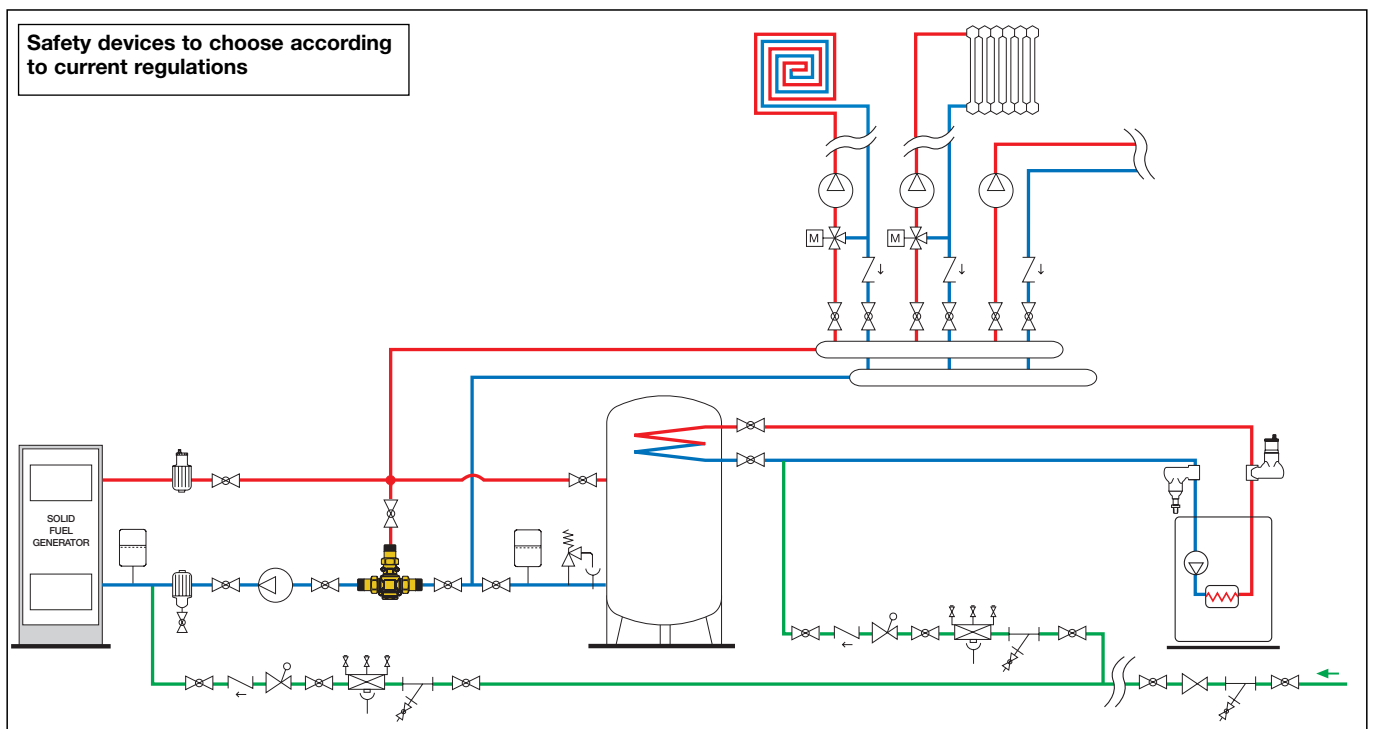

## SPECIFICATION SUMMARY

### 280 series

Anti-condensation valve. Size DN 20 (from DN 20 to DN 32). Connections 3/4" (from 3/4" to 1 1/4") M (ISO 7/1) with union. Brass body. Brass cap. PSU obturator. Stainless steel spring. EPDM seal. Wax thermostatic sensor. Medium water and glycol solutions. Maximum percentage of glycol 50%. Maximum working pressure 10 bar. Working temperature range 5–100°C. Setting temperatures 45°C, 55°C, 60°C, 70°C. Setting accuracy  $\pm 2^\circ\text{C}$ . By-pass complete closing temperature  $T_{set} + 10^\circ\text{C}$ .

We reserve the right to change our products and their relevant technical data, contained in this publication, at any time and without prior notice.